

AREA STATEMENT

FLOOR	FLOOR AREA (SQ.M)	PERMITTED FLOOR AREA (SQ.M)	OVERAGE (%)
GROUND FLOOR	211.868	211.868	0
FIRST FLOOR	211.868	211.868	0
SECOND FLOOR	211.868	211.868	0
THIRD FLOOR	211.868	211.868	0
FOURTH FLOOR	211.868	211.868	0
ROOF TERRACE	211.868	211.868	0
TOTAL	1059.296	1059.296	0

DOORS AND WINDOWS SCHEDULE

DOOR	NO.	WIDTH	HEIGHT	WINDOW	NO.	WIDTH	HEIGHT
D01	1	1.100	2.100	W01	1	1.800	1.300
D02	2	0.900	2.100	W02	1	1.800	1.300
D03	3	0.750	2.100	W03	1	1.800	1.300
D04	4	1.300	2.100	W04	1	1.800	1.300
D05	5	1.400	2.100	W05	1	1.800	1.300
D06	6	1.450	2.100	W06	1	1.800	1.300
D07	7	1.400	2.100	W07	1	1.800	1.300
D08	8	1.450	2.100	W08	1	1.800	1.300
D09	9	1.400	2.100	W09	1	1.800	1.300
D10	10	1.450	2.100	W10	1	1.800	1.300

CAR PARKING CALCULATION

NO. OF REG. CAR PARKING	NO. OF UNREG. CAR PARKING	TOTAL NO. OF CAR PARKING
14	0	14
14	0	14
TOTAL	0	14

F.A.R. CALCULATION

F.A.R. = 2018.566/307.189 = 6.57

C.B. & LOFT AREA STATEMENT

FLOOR	FLOOR AREA (SQ.M)	PERMITTED FLOOR AREA (SQ.M)	OVERAGE (%)
GROUND FLOOR	211.868	211.868	0
FIRST FLOOR	211.868	211.868	0
SECOND FLOOR	211.868	211.868	0
THIRD FLOOR	211.868	211.868	0
FOURTH FLOOR	211.868	211.868	0
ROOF TERRACE	211.868	211.868	0
TOTAL	1059.296	1059.296	0

NOTES

- ALL DIMENSIONS ARE IN METERS.
- ALL EXTERNAL WALLS ARE 200 TH AND INTERNAL WALLS ARE 75 TH IF NOT NOTATED OTHERWISE.
- SCALE: 1:100.
- SAFE BEARING CAPACITY OF SOIL 7 MT/RS.M ASSUMED.
- DEPTH OF SEPTIC TANK AND S.U.G. WATER RESERVOIR WILL NOT EXCEED THE DEPTH OF BUILDING FOUNDATION.
- ALL SORTS OF PRECAUTIONARY MEASURE WILL BE TAKEN AT THE TIME OF CONSTRUCTION.

DECLARATION OF OWNER

I DO HEREBY DECLARE WITH FULL RESPONSIBILITY THAT I WILL ENGAGE ARCHITECT (E.S.E.) DURING CONSTRUCTION. I WILL FOLLOW THE INSTRUCTION OF ARCHITECT (E.S.E.) DURING CONSTRUCTION OF THE BUILDING AS PER SANCTION PLAN. RAJAPUR SONARPUR MUNICIPALITY STRUCTURE WORK SUBMITTED DOCUMENTS IF FOUND TO BE FAKE AUTHORITY WILL REVOKE THE SANCTION PLAN. RAJAPUR SONARPUR MUNICIPALITY STRUCTURE WORK SUBMITTED DOCUMENTS IF FOUND TO BE FAKE AUTHORITY WILL REVOKE THE SANCTION PLAN. RAJAPUR SONARPUR MUNICIPALITY STRUCTURE WORK SUBMITTED DOCUMENTS IF FOUND TO BE FAKE AUTHORITY WILL REVOKE THE SANCTION PLAN.

CERTIFICATE OF STRUCTURAL ENGINEER

THE STRUCTURAL DESIGN AND DRAWING OF BOTH FOUNDATION AND SUPER STRUCTURE OF THE BUILDING HAS BEEN MADE BY ME CONSIDERING ALL POSSIBLE LOADS INCLUDING THE SEISMIC LOAD AS PER THE NATIONAL BUILDING CODE OF INDIA AND CERTIFIED THAT IT IS SAFE AND STABLE IN ALL RESPECT.

CERTIFICATE OF L.B.S.

WE HEREBY CERTIFY THAT THE PLANS OF THE PROPOSED BUILDING UNDER A PROVISION OF RAJAPUR SONARPUR MUNICIPALITY HAVE BEEN PREPARED IN CONFORMANCE WITH ALL RELEVANT PROVISIONS OF WEST BENGAL MUNICIPAL BUILDING RULES 2007 AS AMENDED TIME TO TIME.

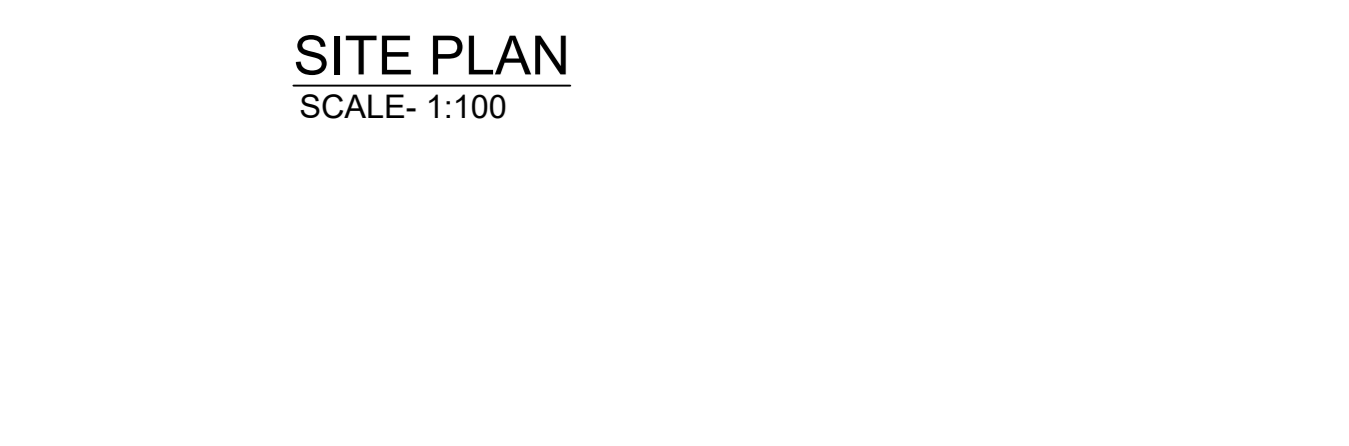
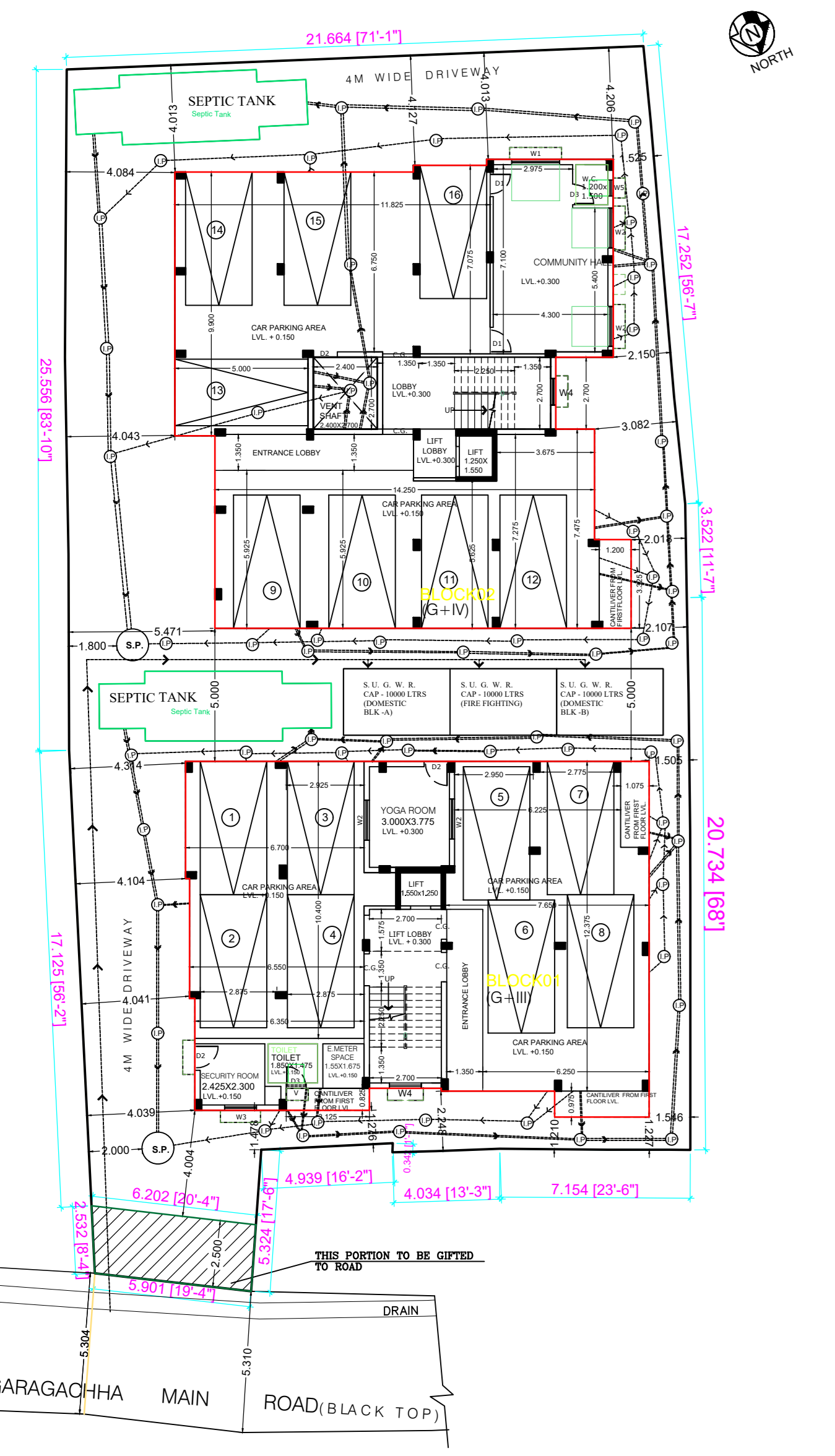
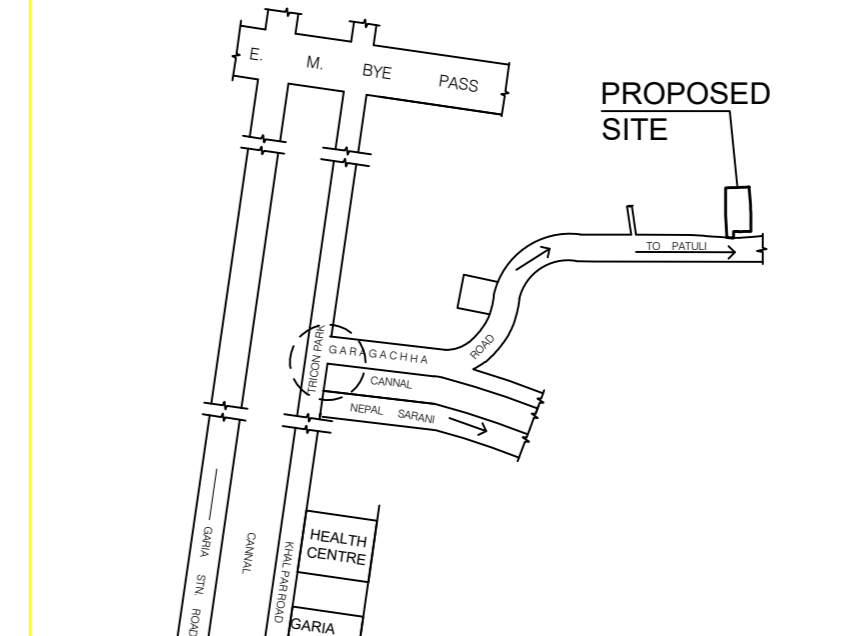
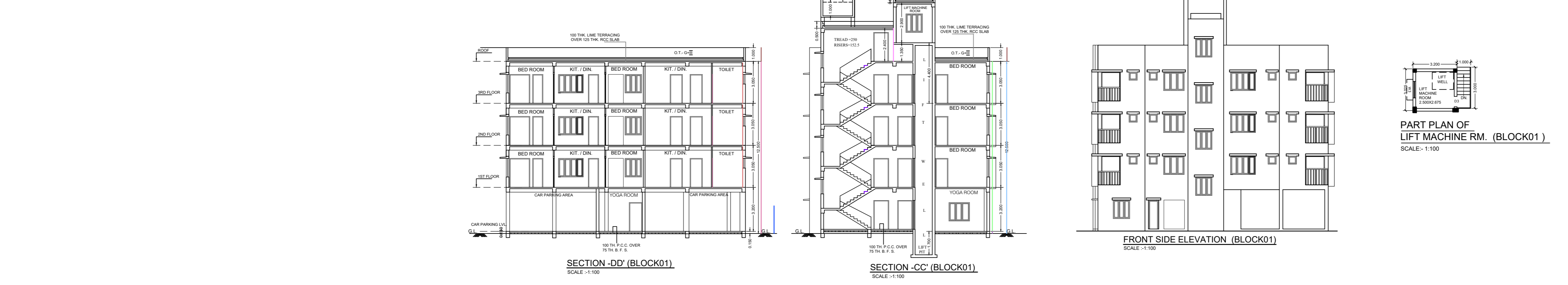
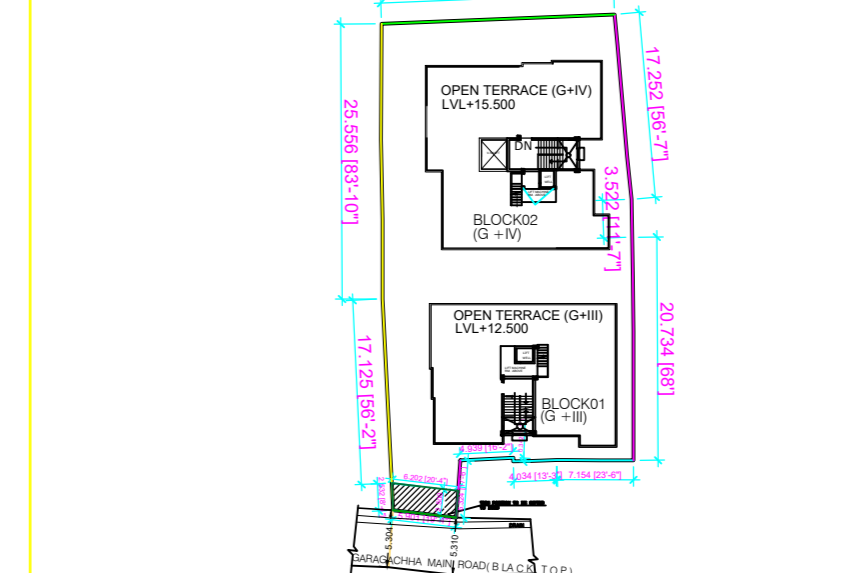
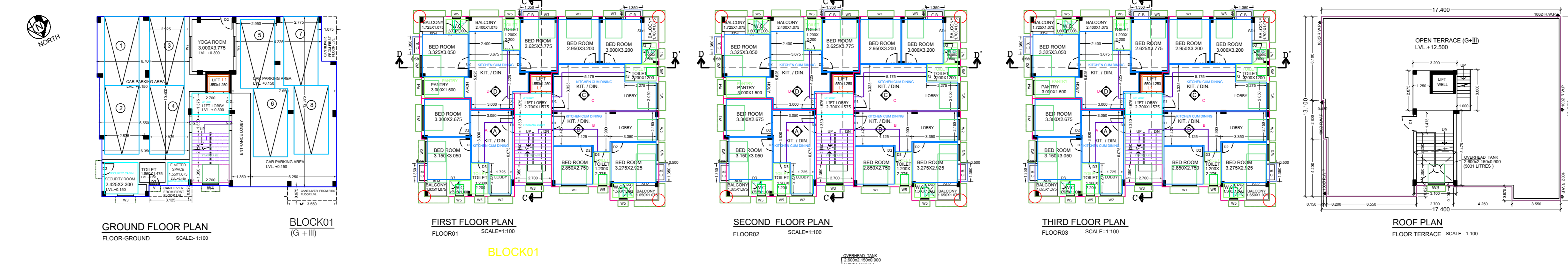
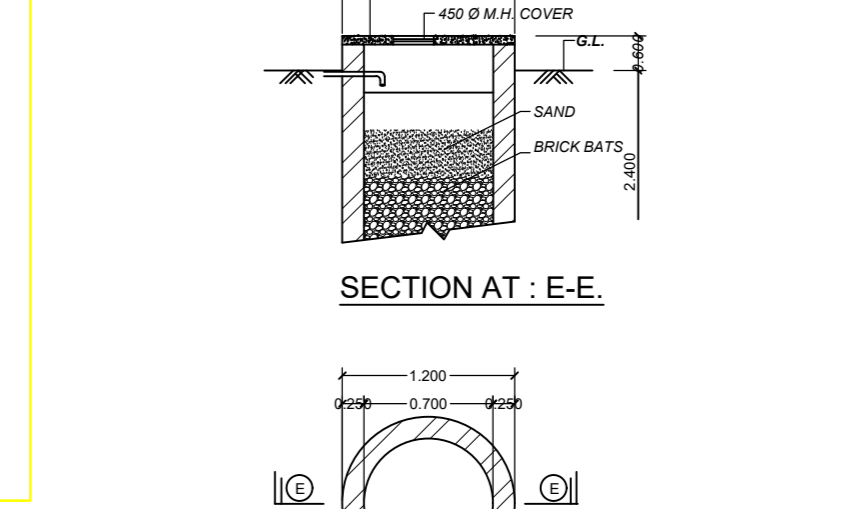
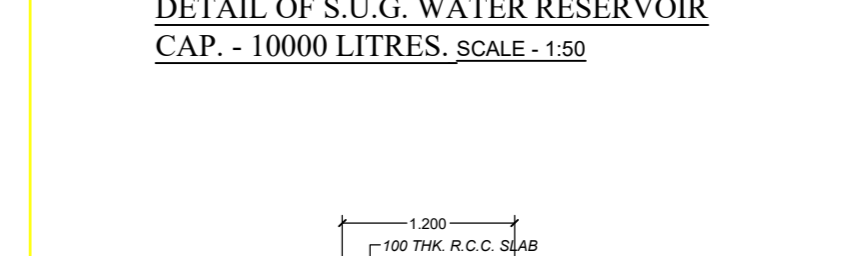
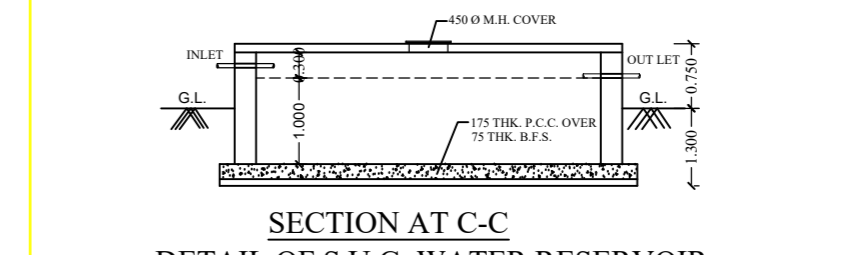
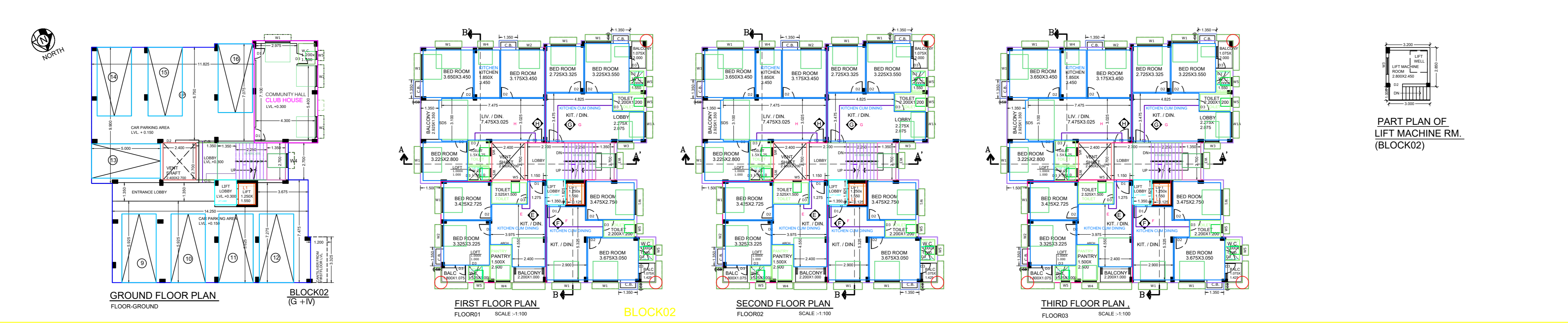

For SURVEY & CONSTRUCTION
South Bank Partner
Smita Sarkar Partner

